



AFL Industries, 1101 West 13th St, Riviera Beach, FL 33404
PHONE: (561) 848-1826 FAX: (561) 848-9454
E-Mail: Sales@aflindustries.com

**AFL-STD
MODEL
OSV-8**

**INSTALLATION, OPERATION &
MAINTENANCE BROCHURE**

AFL INDUSTRIES
1101 WEST 13TH STREET
RIVIERA BEACH, FL 33404

TABLE OF CONTENTS

About the Product	Page 1
Installation Instructions	I-O-M: 12.1
General Instructions	I-O-M: 0.01
Operation & Maintenance Instructions	I-O-M: 8.10
Oil Stop Valve Maintenance	I-O-M: 12.7
Equipment Specifications	Contract
8" □ Oil Stop Valve	Drawing
Float Guide Lift Cable	Drawing

The Oil Stop Valve by AFL

The AFL Oil Stop Valve prevents discharge of separated oil to sewers and streams.

Features:

- Dependable gravity operation
- Single moving part
- Large flow capacity
- Self-opening (optional)
- No power requirement
- Corrosion resistant construction
- Flow rates to 1400 GPM through a single valve
- Discharge heights and direction can be custom engineered for your specific application.
- ASTM 150 Lb. bolt together discharge flanges are available upon request.
- High water flashing light and or audible alarms are available. Either on site or remote.

Large, unpredictable oil spills can defeat the most conservatively designed pollution control system.

But while the cost of such a system can be prohibitive, the consequences of not controlling a spill can be equally catastrophic. The AFL Oil Stop Valve (OSV) is designed to solve these problems.

Oil Stop Valves confine even large oil spills to the premises. The OSV is available from AFL prepackaged in a fiberglass or steel catch basin or as an option on AFL oil/water separators. In addition, the OSV is available separately for installation in existing separators, catch basins or manholes.

The OSV has only one moving part, a ballasted float set at a specific gravity between that of oil and water. When an oil spill occurs, the float loses buoyancy as the oil level increases until it finally seats itself on the discharge port. Thus, the oil spill is confined.

The Oil Stop Valve is fabricated from non-corrosive PVC and stainless steel. Standard sizes are 4", 6", 8", 10", 12" discharge piping. Larger piping systems can be accommodated by manifolding units together. Optional screening can be provided if necessary to prevent the discharge of large floating solids.

Consider the OSV for those applications where oil spills are possible, but unpredictable such as electrical transformers, oil storage areas, and transportation fueling systems. The Oil Stop Valve is the most cost effective method to prevent a major disaster.

1. Lower valve into manhole.
2. Using PVC cement, glue outlet pipe (supplied by AFL) into discharge elbow.
3. Align outlet pipe to manhole outlet pipe to check for proper elevation
4. Move valve approximately 6" away from manhole outlet pipe.
5. Install AFL supplied flexible PVC boot and clamps onto valve outlet pipe DO NOT tighten at this time.
6. Reposition valve to allow PVC boot to connect to manhole outlet pipe.
7. Tighten clamps.
8. Install AFL supplied fiberglass hold down strap over horizontal pipe between the bottom elbows.
9. Using the pre-drilled hole in the strap as a template, mark the location of the 3/8" anchor bolts.
10. Remove strap and install anchors.
11. Replace the strap and secure in place.
12. Measure the distance from the underside of the manhole to the top of the 1" union on the discharge elbow.
13. Cut the 1" PVC pipe (not by AFL) to previously measured length.
14. Remove the top portion of union from the valve and glue the pipe into the union.
15. Install the union and the pipe to the valve making sure the union "O" ring is in place.
16. Attach float lift cable to the top of the manhole where it can be easily reached from the manhole cover area to manually open the valve when necessary and to keep the cable from getting caught between the valve float and the valve seat.
17. Fill the manhole with clean water until it reaches the invert of the outlet.
18. Pull up slightly on lift cable to make sure float is free of seat.
19. Test float by pushing downward on float guide rod. If movement occurs, release pressure and rod will rise to original position.
20. Using cable ties, connect lift cable and handle to previously installed eyebolt while allowing the float to travel downwards approximately 12"

**UNIT IS NOW READY FOR SERVICE
I.O.M. 12.1**

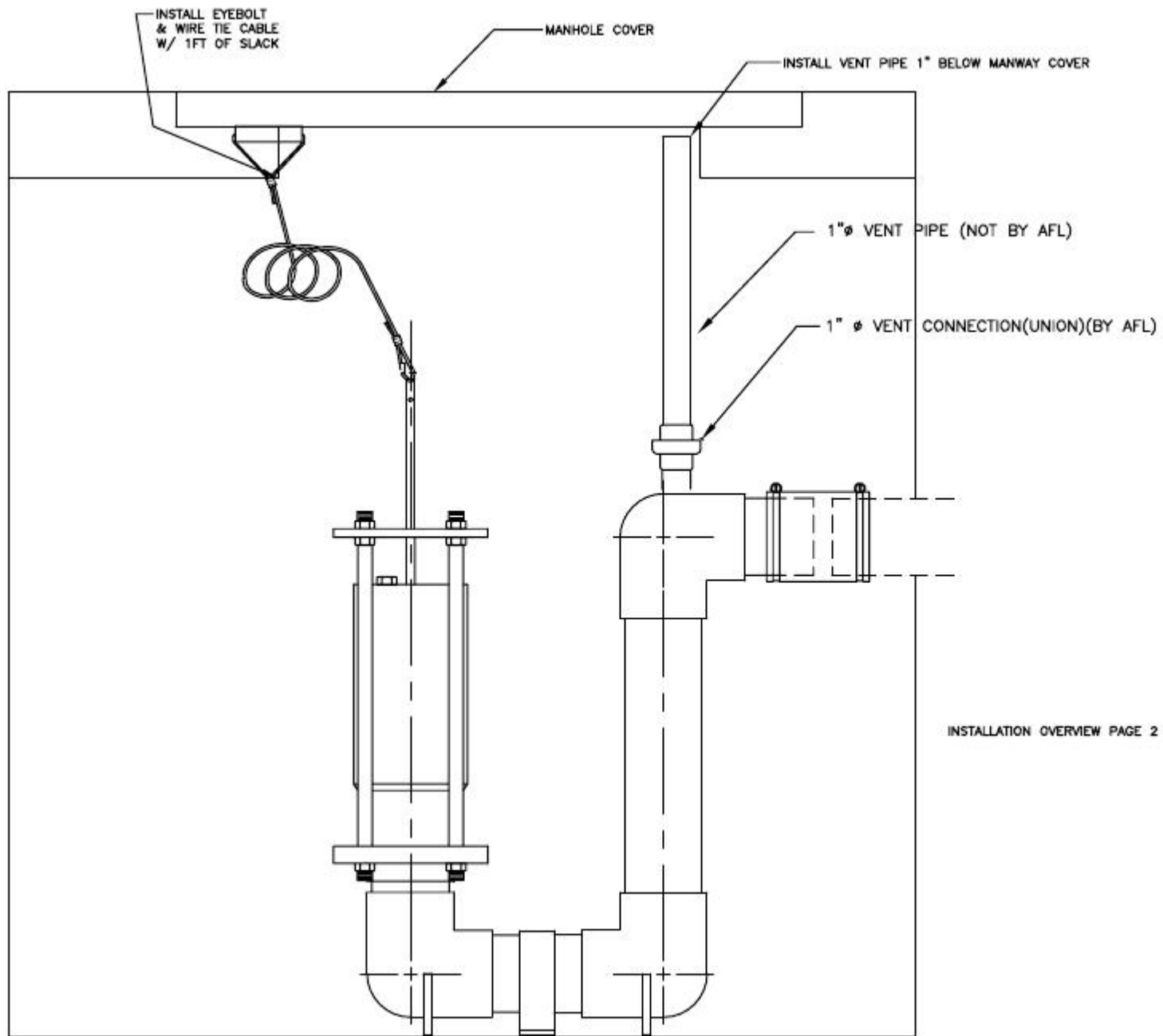

I-O-M: 12.1

**SERVICE
MANUAL**

**GENERAL
INSTRUCTIONS**

Page 1 OF 1

PRODUCT:

OIL STOP VALVES

CONTRACTOR - PLEASE READ THIS

INSTRUCTION CAREFULLY

AFL Industries provides you with several valuable aids, and the few minutes you spend reading this instruction will save you hours later. The purpose of this instruction is to acquaint you with the equipment-erecting knowledge which you now have at your fingertips.

THE INFORMATION CONTAINED IN THESE INSTRUCTIONS IS BASED ON YEARS OF EXPERIENCE WITH THE ERECTION OF OUR EQUIPMENT, BUT IS INTENDED AS A GUIDE ONLY. THE EQUIPMENT WHICH YOU HAVE AVAILABLE TO YOU MAY DICTATE OTHER, MORE CONVENIENT, PROCEDURES, BUT THE FINAL RESPONSIBILITY FOR SELECTION OF ERECTION PROCEDURES OR TOOLS IS NOT BORNE BY AFL INDUSTRIES, INC.

IOM BROCHURE

This brochure contains the heart of the information necessary to erect the equipment. It is structured as follows:

1. Title Page and General Instructions;
2. Table of Contents - listing of descriptions and reference numbers for all drawings;
3. Specific Contract Information.

The complete section of information provided for each contract includes:

1. Contract Equipment Specification - a written description of the equipment;
2. Installation Instructions - a general erection instruction for the equipment provided;
3. Assembly Drawings - showing the unit and its various components;
4. Operation and Maintenance Instructions;

FURTHER ASSISTANCE

The erection aids material provided by AFL should enable you to install, operate, and maintain the equipment. This instruction is provided to help you to help yourself, and therefore, to save you time and expense. If a problem is encountered in installing or operating the equipment which cannot be solved by referring to the available material, please feel free to contact us. Address your inquiry to our Technical Service Department, AFL Industries, Inc., 1101 West 13TH Street., Riviera Beach, Florida 33404, or call us at 561-848-1826. Our website address is **WWW.AFLINDUSTRIES.COM**.

PRODUCT: OIL STOP VALVE

PRINCIPLE OF OPERATION

The valve operates on a buoyancy principle. The ballasted float, which is the only moving part, is weighted for a specified gravity of 0.95. In the water, the float will float and keep the valve open.

An accumulation of oil around the float will decrease the buoyant force on the float causing it to float lower in the liquid. As the oil accumulation increases, the float will sink lower and finally close the valve when the oil level is approximately 3" to 4" above the bottom of the float.

OSV OPERATION

The AFL Oil Stop Valve (OSV) is designed for easy, efficient operation in confining oil spills to the premises. It is used in oil/water gravity differential separators, coalescing type separators and oil manholes to prevent the entry of oil into the effluent.

Features of the valve include:

1. Dependable gravity operation
2. Corrosion-resistant construction
3. Only one moving part
4. Outlet vent connection (siphon breaker)

The valve is available in a variety of sizes to meet a wide range of flow conditions.

The valve is supplied as an option on AFL oil/water separators and oil interceptors. It can also be provided independently for existing applications for similar equipment.

Occasionally valves are fabricated with a "weep hole" which facilitates reopening of the valves after closure due to oil spill. The weep hole equalizes the pressures in the valve and will pass a minimal amount of oil/water mixture. **This option is only added upon the customer's written request.**

On applications where this minimal discharge is objectionable, the weep hole is eliminated. In such cases, and after the valve closes due to oil spill, the valve must be re-opened manually by lifting the float by pulling on lift cable.

WARNING: UPON VALVE CLOSURE, DUE TO A SPILL, THE OIL COLLECTED IN THE SUMP, TANK OR OIL SEPARATOR, MUST BE EVACUATED FROM THE VALVE CHAMBER AND DISPOSED OF PROPERLY. AFTER THE OIL HAS BEEN REMOVED, FILL CHAMBER WITH CLEAN WATER AND RE-OPEN THE VALVE BY LIFTING THE FLOAT BY PULLING ON LIFT CABLE. THE SAME PROCEDURE MUST BE USED DURING PROCESS START UP.

THE ABOVE DESCRIBED PROCEDURE ON RE-OPENING OF THE VALVE IS ESPECIALLY CRITICAL ON STOP VALVES WITHOUT WEEP HOLES.

PRODUCT:

OIL STOP VALVE

ASSEMBLY LIST

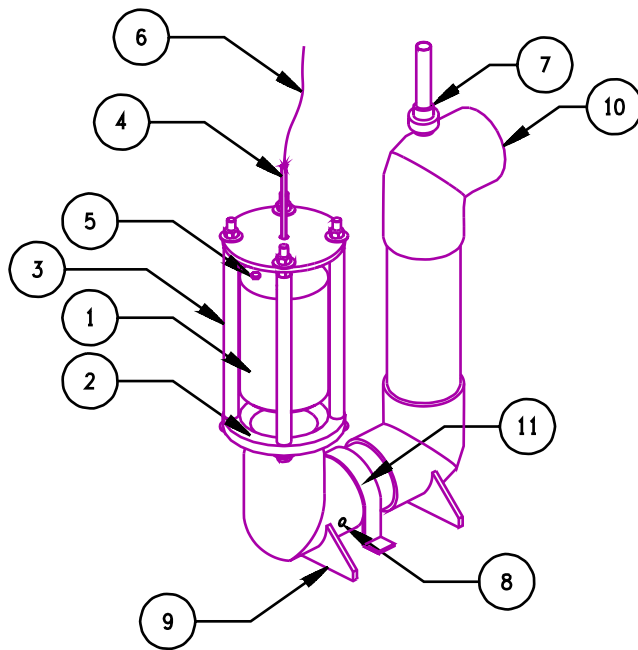

- 1 FLOAT
- 2 FLOAT SEAT
- 3 RETAINING RODS
- 4 FLOAT GUIDE
- 5 BALLAST ACCESS HOLE
- 6 1/8"Ø MANUAL RELEASE CABLE
- 7 1"Ø SIPHON BREAKER UNION
(SIPHON BREAKER PIPE NOT BY AFL.)
- 8 WEEP HOLE
- 9 LEGS
- 10 DISCHARGE ELBOW
- 11 HOLD-DOWN STRAP

INSTALLATION INSTRUCTIONS:

NOTE: OSV discharge pipe (Plain ends) are shipped loose (not glued to the discharge elbow). The contractor, at his discretion, may solvent glue to the valve discharge elbow, or select other suitable means for connecting OSV

PRODUCT: OIL STOP VALVE

discharge to outlet pipe.

a) Plain End Connections

All valves with plain end connections are supplied with PVC coupling and two stainless steel worm drive hose clamps. Slide the coupling on valve discharge and install the clamps by sliding them on the coupling.

Line up the valve discharge with outlet pipe, leave 1/4" gap between pipe ends, and slide this coupling and clamp on the outlet pipe. Do not tighten the hose clamps at this time.

b) Flanged End Connections

Line up the flange bolt holes, insert a gasket and bolt flanges. Do not tighten bolts at this time.

WARNING: FLANGES SUPPLIED WITH THE VALVES ARE FLAT FACE; MAKE SURE THE MATING FLANGE IS OF THE SAME DESIGN. USE OF RAISED FLANGES WILL BREAK THE PVC FLANGES.

C. Anchorage

1. OSV valves are supplied with hold down straps, which are designed to secure the valves to the concrete. After the valve has been lined up with outlet nozzle, install the strap on the valve body and use the two holes as a template for locating the anchor bolts.
2. Remove straps and drill in anchors.
3. Replace the strap and bolt down the strap.

D. Siphon Breaker

1. Siphon breaker connection is located on the valve discharge elbow and is furnished with a union to facilitate installation of siphon breaker pipe.
2. In order to calculate siphon breaker pipe length, determine the maximum liquid level in the sump/tank at a spill condition, subtract elevation of the top of the OSV discharge pipe from maximum liquid level and add 1'-6".

After the length of the pipe has been cut, attach the pipe to the union using PVC solvent cement.

Install the siphon breaker pipe on the valve and support it as required.

NOTE: Ideally, the top of the pipe should be as close to grade as possible.

WARNING: IMPROPER SIPHON PIPE ELEVATION WILL RESULT IN OIL DISCHARGE THROUGH THE SIPHON BREAKER DURING SPILL CONDITION.

CAPACITIES

A minimum recommended water level, sufficient to completely submerge the float housing, is required for proper operation of the OSV. Operation at less than the minimum recommended water level will reduce the capacity of the OSV.

The recommended operating flow rate versus its associated head loss is shown in **Figures 2.01 through 2.03**.

NOTE: For the valve to operate properly at required flow(s), the valve discharge pipe centerline must be below the liquid level at a distance equal to (or greater than) the associated head loss.

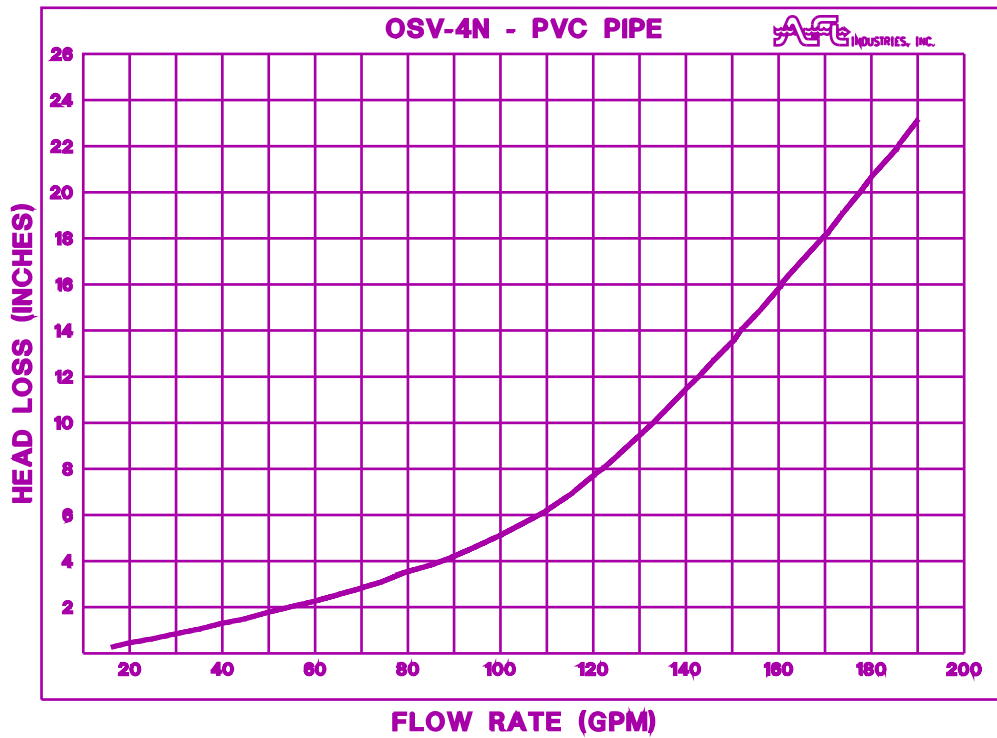

Figure: 2.01 OSV-4 HEAD LOSS VS. FLOW RATE

WARNING: IF THE VALVE IS OPERATED AT GREATER THAN DESIGN OR RECOMMENDED FLOWS IT MAY SHUT OFF AUTOMATICALLY, WHICH MAY NECESSITATE THAT THE VALVE BE REOPENED MANUALLY.

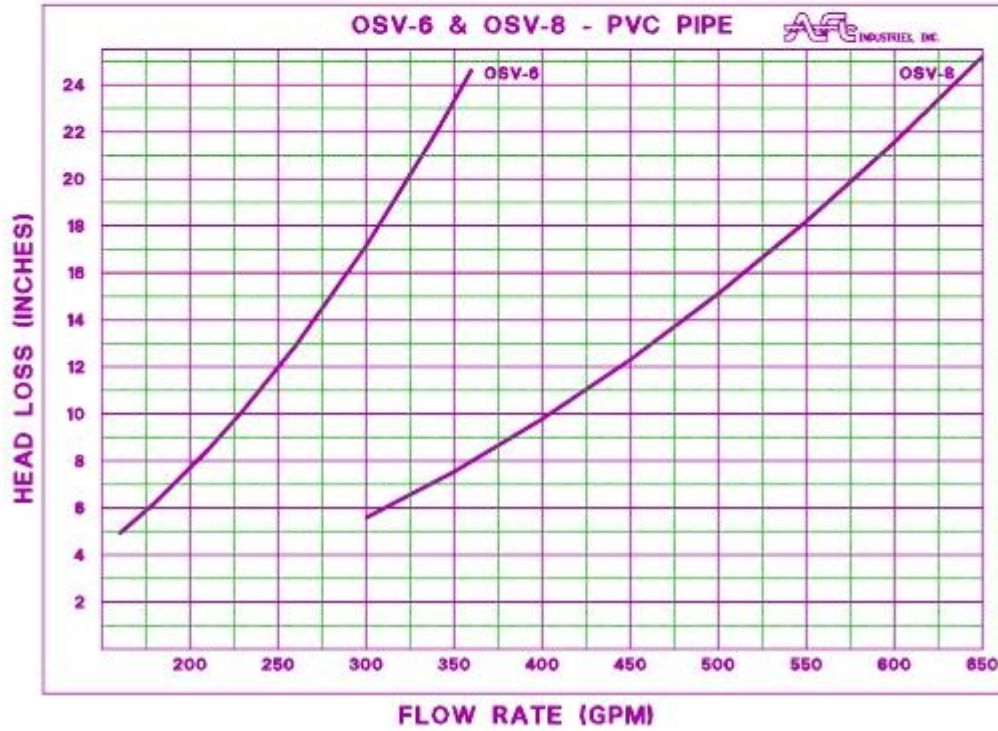

FIG. 2.02

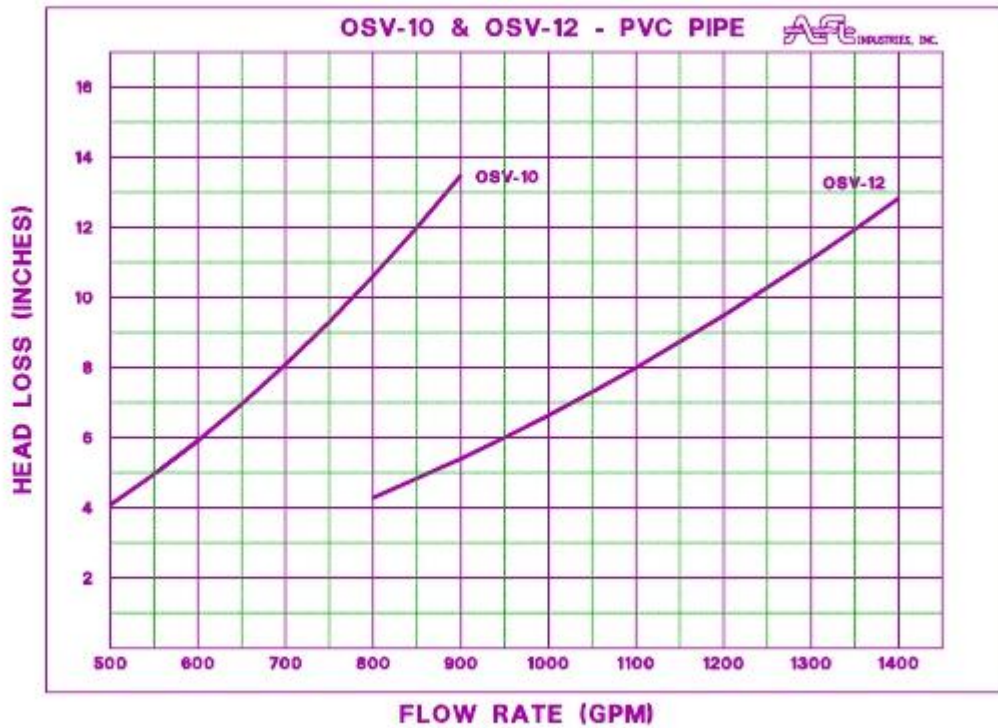

FIG. 2.03

OSV MAINTENANCE

Please read entire page before performing maintenance

- 1.** Remove floating debris.
- 2.** Remove solids from bottom of sump as required. 6” of build up maximum.
- 3.** With water level in sump at outlet invert gently push guide rod downwards approximately 6”. This will allow float to come in contact with the bottom flange.
- 4.** Release guide rod. The rod should rise up to the original position. If this procedure was successful the valve is in proper working order. Occasionally the float will stay seated on the bottom flange when pushed down. Simply pull upwards on the stainless steel cable attached to the guide rod. This will break the suction and allow the float to rise. If when attempting to push guide rod downwards and it appears to be stuck, pull up on stainless steel cable to raise the float again approximately 6”. If float rises release cable. If the float sinks it is inoperable and must be replaced.
- 5.** This procedure should be performed at least yearly.
- 6.** No other maintenance is required.

**AFL INDUSTRIES
1101 WEST 13TH STREET
RIVIERA BEACH, FL 33404**

AFL OIL STOP VALVE SPECIFICATION

Application	Oil Spill Prevention
Model Number	OSV-8
Number of Units	One (1)

Each unit will conform to the following specifications:

Description	Fabricated control valve designed to control Oil spills. Valve assembly shall consist of Base, guides, inlet housing, float, and Outlet connection. Valve shall be designed To operate on specific gravity differential principle.
Float Weight	Ballasted for 0.95 Sp. Gr.
Flow	600 GPM Gravity (MAX.)
Inlet Size	8" Diameter
Outlet Connection	8" Diameter plain end pipe with flexible Connector and clamps. 1" diameter Socket-type connection for siphon breaker. Siphon breaker, pipe and connection NOT BY AFL . Plain end pipe, flexible Connector and clamps supplied loose.

Materials of Construction

Base, Housing & Outlet Piping	PVC
Float	SST w/Sch. 80 PVC Seat

**AFL INDUSTRIES
1101 WEST 13TH STREET
RIVIERA BEACH, FL 33404**

Float Guides

Type 304 Stainless Steel & PVC sleeves.

Design Requirements:

Pressure Rating

Atmospheric

Temperature

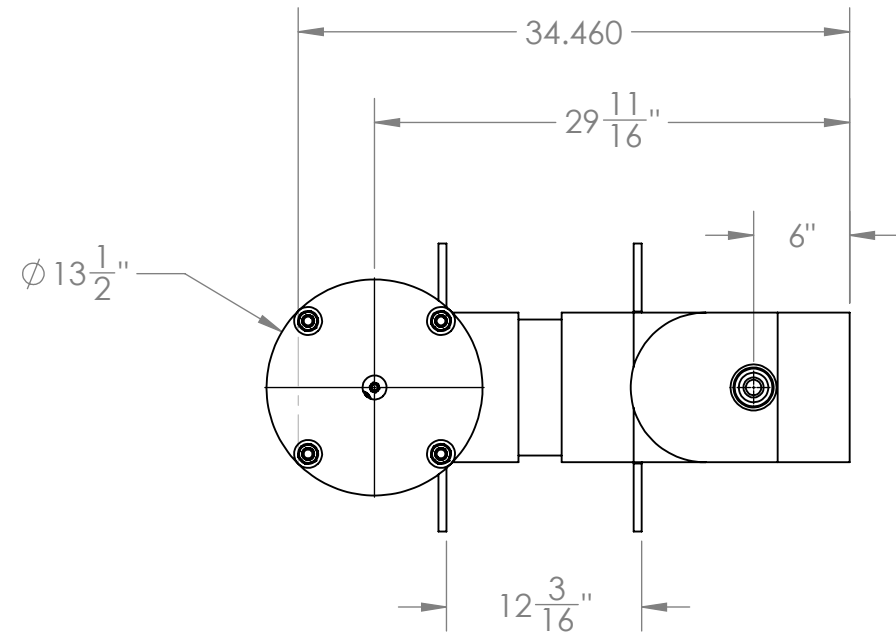

Ambient with 130°F maximum

Valve to be shipped completely assembled by **AFL INDUSTRIES** for field installation by customer.

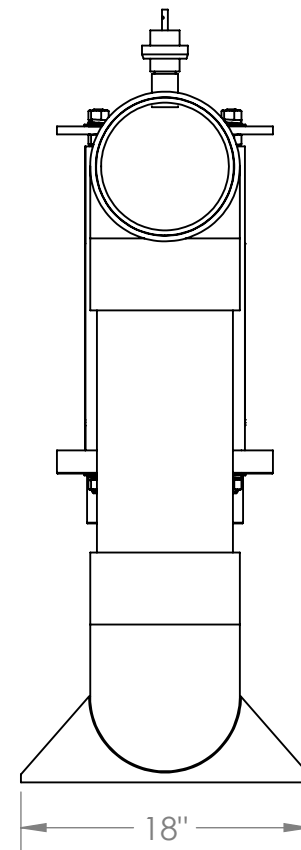
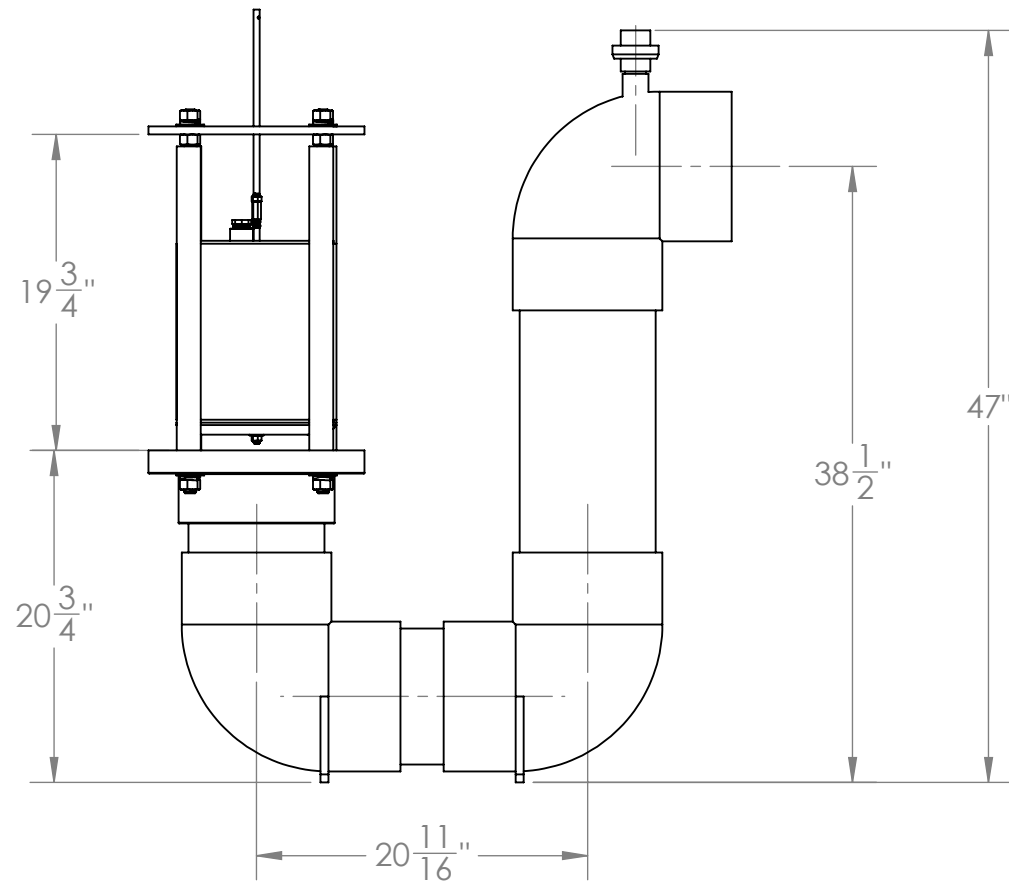
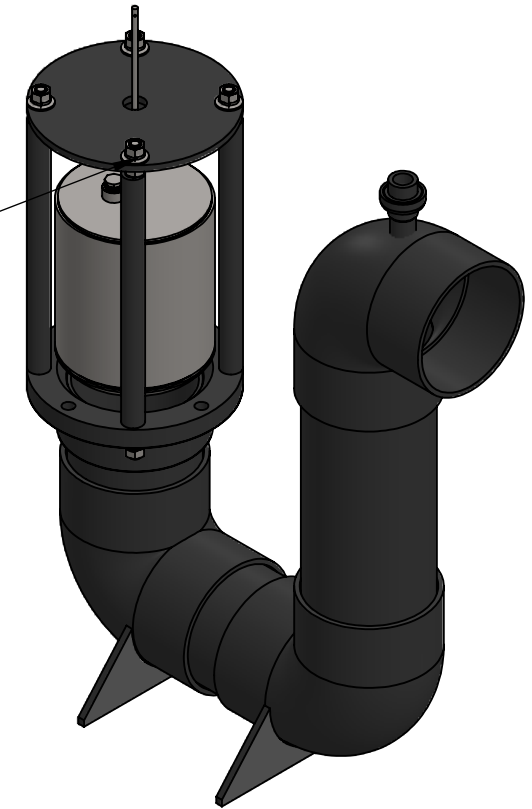

ATTACH 1/16" X 10' SS CABLE FOR MANUAL OPERATION



 AFL INDUSTRIES, INC. 1101 WEST 13TH STREET RIVIERA BEACH, FLORIDA 33404	UPPER ASSEMBLY		NAME	DATE	TITLE: OSV 8 INCH PVC GENERAL ARRANGEMENT	
	UNLESS OTHERWISE SPECIFIED: DIMENSIONS ARE IN INCHES TOLERANCES: FRACTIONAL $\pm 1/32$ ANGULAR: $X^\circ \pm 1^\circ$ TWO PLACE DECIMAL $\pm .025$ THREE PLACE DECIMAL $\pm .0125$	INTERPRET GEOMETRIC TOLERANCING PER: ASME Y14.5M MATERIAL	USED ON	DRAWN		JRH
FINISH		PROPRIETARY AND CONFIDENTIAL THE INFORMATION CONTAINED IN THIS DRAWING IS THE SOLE PROPERTY OF RGF ENVIRONMENTAL, INC. ANY REPRODUCTION IN PART OR AS A WHOLE WITHOUT THE WRITTEN PERMISSION OF RGF ENVIRONMENTAL, INC. IS PROHIBITED.		APPROVED	SS	08/12/2015
DO NOT SCALE DRAWING		THIRD ANGLE PROJECTION 		SIZE B		DWG. NO. OSV 8IN PVC
REV -						
SHEET 1 OF 5						