



By *RGF*[®]

WE ARE RGF[®]

Deslimer[®] Condensate Drain Pump

Dual-Action Pump Clears Blockages Fast

Condensate drain lines are prone to clogging as bacterial slime builds up in wet HVAC systems. When blocked, drain pans can overflow, causing water damage and system shutdowns.

Deslimer[®] easily clears stubborn blockages with a few quick pumps. Its dual-action design generates powerful suction and pressure to break up and clear blockages with no chemicals, no compressed air, no hassle.



RGF[®]
ENVIRONMENTAL GROUP, INC.

TO LEARN MORE, VISIT: RGF.COM

Why use RGF® Deslimer®

When it comes to cleaning clogged HVAC condensate drain lines, not all tools are created equal. Deslimer® was designed to overcome the limitations of conventional drain cleaning products, offering a more durable, technician-friendly solution.

- No CO2 cartridges, chemicals or power cords
- Durable aluminum body, won't crack under pressure
- Dual action pump delivers suction and pressure on both strokes
- Easy to use, no set-up time, Deslimer® is always ready to go

Deslimer® Condensate Drain Pump

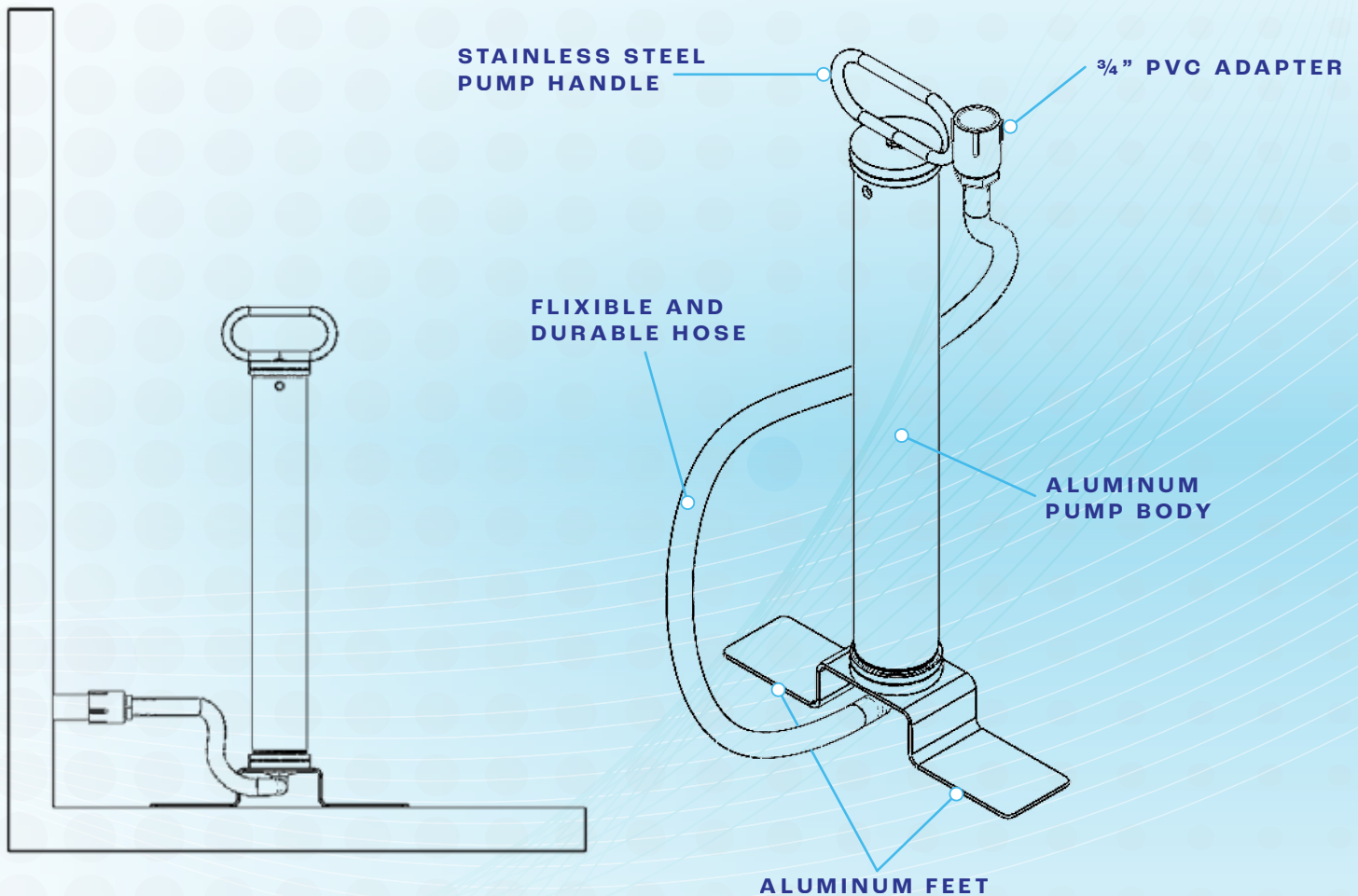

ITEM#	MATERIAL	DIMENSIONS	SHIP WT.
DS-1	Aluminum	22.5"(H) x 11.5"(W) x 2.5"(D)	6 lbs

CONSUMABLE ITEMS

BUNA-N Sealing Washers - Part# DS-SEAL (qty=2)

WARRANTY

1 Year

RGF[®]
ENVIRONMENTAL GROUP, INC.

TO LEARN MORE, VISIT: RGF.COM